

Mounting Instructions
2100 Series Workstation Lighting
Universal Mounting Brackets

- * The light is designed to be mounted using the 2 brackets provided.
- * 2 screws per end are required to safely hold the brackets to the light fixture.
- * 1 screw per end is required to securely hold the brackets to the horizontal mounting track.

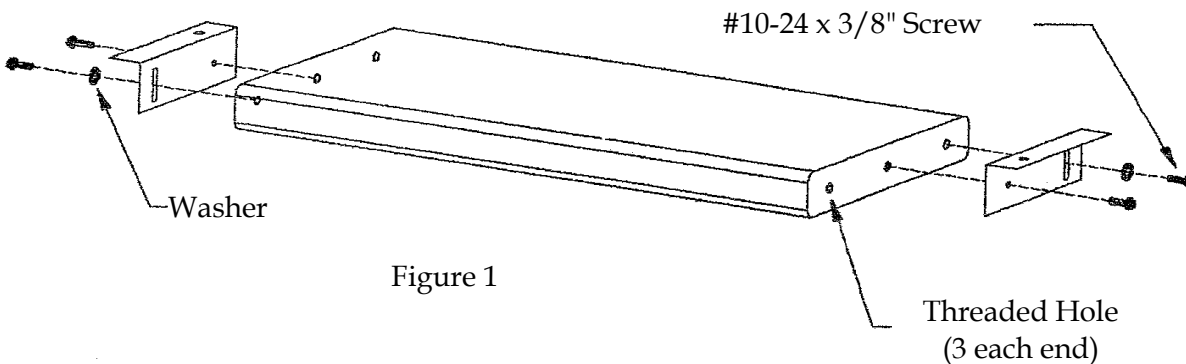

Installation

1. Insert 2 #10-24 screws through bracket into threaded holes on each end of light fixture (see fig. 1) and tighten securely.
2. Insert 1/4-20 Tee Nuts into horizontal mounting track and position light below track.
3. Insert 1/4-20 Screws through bracket into tee nuts and tighten securely.

Note: All brackets, screws & washers required are provided with each light.

" Caution"

- * Injury to person and damage to the light and/or mounting surface may result if the light is pulled from the surface.
- * Always mount light only to a surface that is mechanically sound to reduce the likelihood of such injury or damage.